

ISOLATING VALVES
VALVES
DN 40 to 300



03/11/2021

RSERV21ENW100

EURO 20 NEW with flanges serie S15 long version PFA16 Standard
(serie S15 ISO = type 21 = long version between flanges)



Gate Valve long version Serie S15:

- In compliance with norm NF EN1074-1 and 2 at 2500 cycles and to NF standards
- French Sanitary conformity ACS (16 ACC NY 293)
- 250 microns blue epoxy powder
- Manufacturing at SG PAM Toul Plant (France)
- Unit hydraulic tests in compliance with NF EN12266-1
- Range in CC and ACC version

References

DN valve	Closing direction	Description	References PN10	References PN16	Mass PN10	Mass PN16
mm		Version			kg	kg
40	Anti-clockwise	Cap	RBA40ADCH	RBA40ADCH	9.4	9.4
50	Anti-clockwise	Cap	RBA50ADCH	RBA50ADCH	11.0	11.0
60	Anti-clockwise	Cap	RBA60TDJH	RBA60TDJH	13.6	13.6
65	Anti-clockwise	Cap	RBA65TDCH	RBA65TDCH	13.6	13.6
80	Anti-clockwise	Cap	RBA80ADCH	RBA80ADCH	15.3	15.3
100	Anti-clockwise	Cap	RBB10ADCH	RBB10ADCH	20.0	20.0
125	Anti-clockwise	Cap	RBB12ADCH	RBB12ADCH	26.6	26.6
150	Anti-clockwise	Cap	RBB15ADCH	RBB15ADCH	36.1	36.1
200	Anti-clockwise	Cap	RBB20ADBH	RBB20ADAH	54.1	53.7
250	Anti-clockwise	Cap	RBB25ADBH	RBB25ADAH	92.0	92.0
300	Anti-clockwise	Cap	RBB30ADBH	RBB30ADAH	152.8	152.8

DN valve	Closing direction	Description	References PN10	References PN16	Mass PN10	Mass PN16
mm		Version			kg	kg
40	Clockwise	Bare shaft	RBA40ABBH	RBA40ABBH	9.1	9.1
50	Clockwise	Bare shaft	RBA50ABBH	RBA50ABBH	10.7	10.7
60	Clockwise	Bare shaft	RBA60ANCH	RBA60ANCH	13.6	13.6
65	Clockwise	Bare shaft	RBA65ANCH	RBA65ANCH	13.6	13.6
80	Clockwise	Bare shaft	RBA80ANCH	RBA80ANCH	15.3	15.3
100	Clockwise	Bare shaft	RBB10ANCH	RBB10ANCH	20.8	20.8
125	Clockwise	Bare shaft	RBB12ANCH	RBB12ANCH	26.6	26.6

ISOLATING VALVES
VALVES
DN 40 to 300



03/11/2021

RSERV21ENW100

DN valve	Closing direction	Description	References PN10	References PN16	Mass PN10	Mass PN16
<i>mm</i>		<i>Version</i>			<i>kg</i>	<i>kg</i>
150	Clockwise	Bare shaft	RBB15ANCH	RBB15ANCH	36.1	36.1
200	Clockwise	Bare shaft	RBB20ABBH	RBB20ABAH	54.1	53.7
250	Clockwise	Bare shaft	RBB25ABBH	RBB25ABAH	92.0	92.0
300	Clockwise	Bare shaft	RBB30ABBH	RBB30ABAH	152.8	152.8

DN valve	Closing direction	Description	References PN10	References PN16	Mass PN10	Mass PN16
<i>mm</i>		<i>Version</i>			<i>kg</i>	<i>kg</i>
40	Clockwise	Cap	RBA40AACH	RBA40AACH	9.4	9.4
50	Clockwise	Cap	RBA50AABH	RBA50AABH	11.0	11.0
60	Clockwise	Cap	RBA60APCH	RBA60APCH	13.6	13.6
65	Clockwise	Cap	RBA65APCH	RBA65APCH	13.6	13.6
80	Clockwise	Cap	RBA80APCH	RBA80APCH	15.3	15.3
100	Clockwise	Cap	RBB10APCH	RBB10APCH	20.8	20.8
125	Clockwise	Cap	RBB12APCH	RBB12APCH	26.6	26.6
150	Clockwise	Cap	RBB15APCH	RBB15APCH	36.1	36.1
200	Clockwise	Cap	RBB20AABH	RBB20AAAH	54.1	53.7
250	Clockwise	Cap	RBB25AABH	RBB25AAAH	92.0	92.0
300	Clockwise	Cap	RBB30AABH	RBB30AAAH	152.8	152.8

(*) DN80 : drilling 8 holes. For drilling 4 holes, please replace the 8th letter of the reference by the letter H.

Dimensions and mass

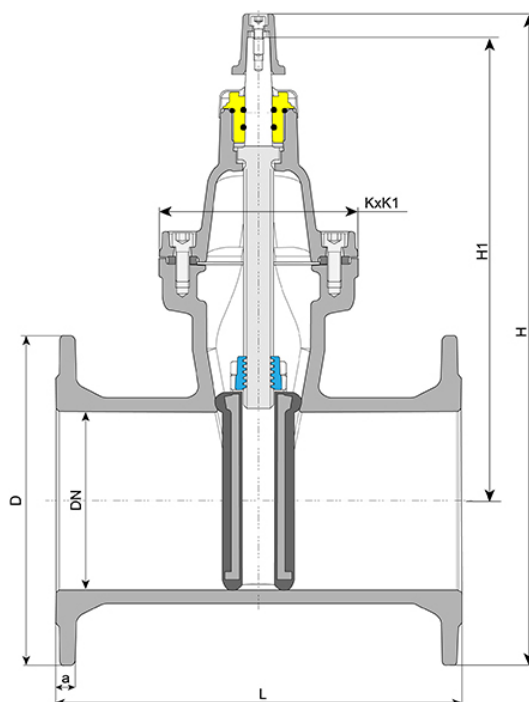

ISOLATING VALVES

VALVES

DN 40 to 300



03/11/2021

RSERV21ENW100

Flanges ISO PN10 or PN16

DN	L	H1	H	D	K x K1	a	Number of turns	S x S	S1 x S1
mm	mm	mm	mm	mm	mm	mm		mm	mm
40	240	227	324.0	150	117 x 135	19	16.5 +/- 1	15.2	14.3
50	250	222	326.5	165	117 x 135	19	16.5 +/- 1	15.2	14.3
60	270	264	373.5	185	105 x 138	19	17.5 +/- 1	18.5	17.3
65	270	264	373.5	185	105 x 138	19	17 +/- 1	18.5	17.3
80	280	288	405.0	200	162 x 143.5	19	21 +/- 1	18.5	17.3
100	300	316	448.0	220	188 x 139	19	23.5 +/- 1	20.6	19.3
125	325	358	501.0	250	225.5 x 161.5	19	28 +/- 1	20.6	19.3
150	350	401	563.0	285	256 x 172	19	33.5 +/- 1	20.6	19.3
200	400	508	728.0	340	350 x 216	20	36 +/- 1	25.7	24.3
250	450	620	875	400	415 x 235	20	44 +/- 1	28.1	24.3
300	500	751	1036	455	476 x 258	25	54 +/- 1	28.1	24.3

Material and coating

DN40 to 250

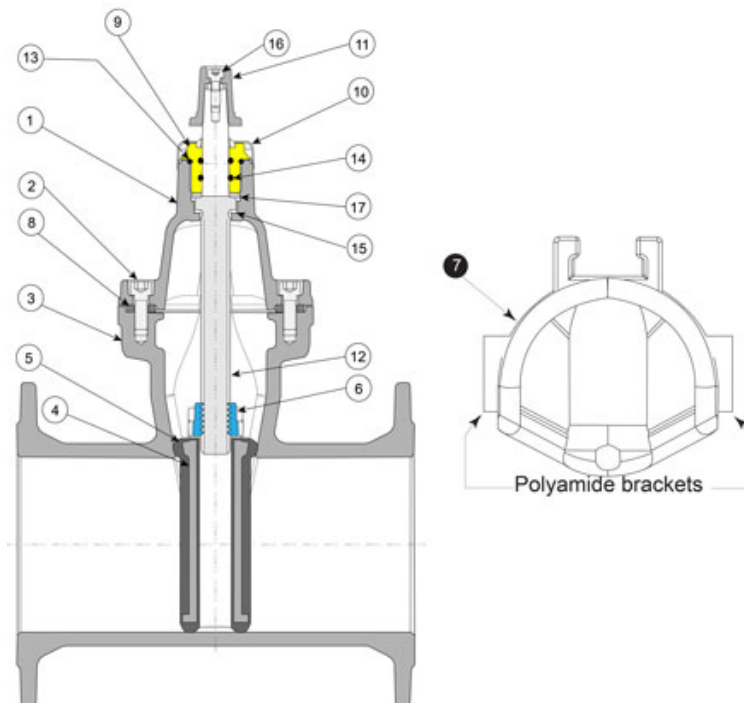

Item	Designation	Material	Coating
1	Bonnet	Ductile iron GS EN GJS 400-15 or 500-7 acc. EN1563	Blue Epoxy (*)

ISOLATING VALVES
VALVES
 DN 40 to 300



03/11/2021

RSERV21ENW100

Item	Designation	Material	Coating
2	Screw	Stainless steel A2-70	-
3	Body	Ductile iron GS EN GJS 400-15 or 500-7	Blue Epoxy (*)
4	Gate core	Ductile iron GS EN GJS 400-15 or 500-7	-
5	Gate protection	EPDM acc. EN681-1	EPDM on ductile iron and polyamide brackets
6	Operating nut	Brass type CuZn39Pb2 acc. EN12164	-
7	Bracket	Polyamide type PA 6-6	-
8	Bonnet-check piece gasket	EPDM Class 70 WA according to EN581	-
9	Bush	Brass type CuZn39Pb2 or CuZn40Pb2 according to EN12164	-
10	Wiper seal	Nitrile NBR 70	-
11	Cap	Ductile iron GS EN GJS 400-15 or 500-7	-
12	Operating stem	Stainless steel X20Cr13 acc. EN10088-3	-
13	O'ring	Nitrile NBR 70	-
14	Seal bush	Nitrile NBR 70	-
15	Thrust washer	Polyamide type PA 6-6	-
16	Screw	Galvanised steel	-
17	Bearing bonnet joint	Polyamide type PA 6-6	-

(*) thickness 250 microns mini average according prescriptions of EN14901

DN300 to 400

ISOLATING VALVES
VALVES
DN 40 to 300



03/11/2021

RSERV21ENW100

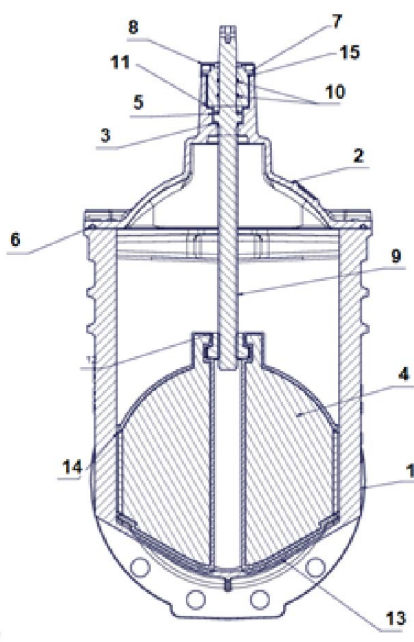

Item	Designation	Material	Coating
1	Body	Ductile iron GS EN GJS 400-15 or 500-7 acc. EN1563	Blue Epoxy (*)
2	Bonnet	Ductile iron GS EN GJS 400-15 or 500-7 acc. EN1563	Blue Epoxy (*)
3	Thrust washer	Polyamide type PA 6-6	-
4	Gate core	Ductile iron GS EN GJS 400-15 or 500-7 acc. EN1563	-
5	Bearing bonnet joint	Polyamide type PA 6-6	-
6	Joint body/bonnet	EPDM	-
7	Bush	Brass type CuZn39Pb2 or CuZn40Pb2 according to EN12164	-
8	Wiper seal	-	-
9	Operating stem	Stainless steel X20Cr13 acc. EN10088-3	-
10	O'ring	NBR	-
11	O'ring	NBR	-
12	Operating nut	Brass type CuZn39Pb2 or CuZn40Pb2 according to EN12164	-
13	Gate protection	EPDM acc. EN681-1	EPDM on ductile iron and polyamide brackets
14	Bracket	Polyamide type PA 6-6	-
15	O'ring	NBR	-
16	Screw	Stainless steel	-

(*) thickness 250 microns mini average according prescriptions of EN14901

Maintenance

Torque for EURO 20 New valves

ISOLATING VALVES
VALVES
 DN 40 to 300



03/11/2021

RSERV21ENW100

DN	Tightening of bush	Tightening of screw body/bonnet
	Nm	Nm
40/50	200	40
65	200	50
80	200	50
100	200	50
125	200	55
150	200	60
200	200	70
250	300	90
300	350	120

Conditioning

DN	SERIE 15		
	Pallet dimensions	Nb pieces	Mass (kg)
40	Europe 1200x800x409	20	218
50	Europe 1200x800x419	20	250
65	Europe 1200x800x439	16	248
80	Europe 1200x800x449	10	183
100	Europe 1200x800x469	10	238
125	Europe 1200x800x494	8	242
150	Europe 1200x800x519	5	210
200	Pallet 1150x1600x535	6	395
250	Pallet 1150x1600x535	4	403