

Butterfly Valve EUROSTOP - Motorized type - PN40



Flanged Butterfly Valve (flange-flange) with joint in the automatic butterfly (JPA) with double eccentricity and long spacing between the flanges.

Ductile iron body and butterfly covered with blue epoxy powder 250 microns mini.

Range from DN150 to DN600mm for pressures of PFA40 bar.

Field of application

Butterfly valves are isolating valves used on water supply networks, in the interconnections of network, in the factories, in pumping stations, on the general networks and on the fire protection networks in the industrial sites.

Butterfly valves are compatible with drinking water and raw water with grid filtration. They will be installed on water networks in factories, in valves chambers or buried.

Their main advantages are:

- Low pressure loss
- Good performance thanks to the choice of the materials, the coatings and the design
- Easy operation per mechanism of the worm type/without end
- Mechanisms equipped with a standardized flange carry-accessory for buried version and motorizable version

Range

The EUROSTOP butterfly valve is available in different configuration: manual, buried service, motorized and motorizable (for this three last configuration see the specific TDS).

Standard version with servomotor S2-15 min, 400 V -3 - 50Hz, IP68, KS protection and heater 230 V.

DN valve	Closing direction	References PN40
<i>mm</i>		
150	Clockwise	RPB15NEEH
200	Clockwise	RPB20NEEH
250	Clockwise	RPB25NEEH
300	Clockwise	RPB30NEEH
400	Clockwise	RPB40NEEH
500	Clockwise	RPB50NEEH
600	Clockwise	RPB60NEEH

ISOLATING VALVES VALVES

DN 150 to 600



06/28/2019

RSEVP21MOT350

Material and coating

Version DN150-600 PN40

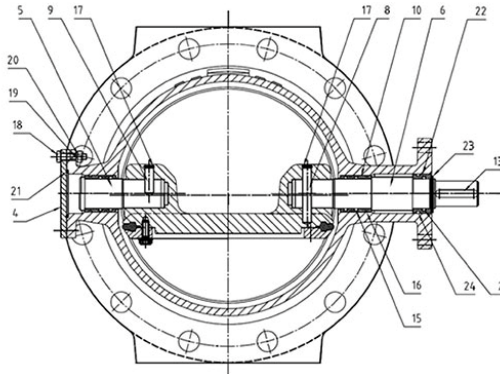
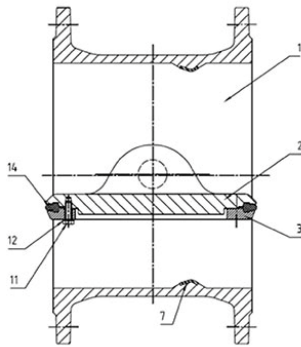

Item	Description	Material	Coating
1	Body	Ductile iron GS500-7	Epoxy powder minimum thickness 250 micron
2	Disc	Ductile iron GS500-7	
3	Retaining ring (*)	Carbon Steel SR235JR	-
4	Cover	Stainless steel X2CrNiMo17-12-2	-
5	Rear shaft	Stainless steel EN 10088 X30Cr13 (420)	-
6	Drive shaft	Stainless steel EN 10088 X30Cr13 (420)	-
7	Seat ring	Stainless steel EN 10088-2 X2CrNiMo 17,12,2 (316L)	-
8	Cylindrical pin (rear shaft)	Stainless steel EN 10088-3 X5CrNiCuNb 16-4 (630)	-
9	Cylindrical pin (drive shaft)	Stainless steel EN 10088-3 X5CrNiCuNb 16-4 (630)	-
10	Bearing	Bronze EN 1982 CuSn12	-
11	Screw	Stainless steel A2	-
12	Spring washer	Stainless steel A2	-
13	Feather key	Steel C40	-
14	Gasket	EPDM	-
15-16	O-ring	EPDM	-
17	Internal circlips	Stainless steel EN 10088-3 X5CrNi 18-10	-
18	Screw	Stainless steel EN 10088-3 X5CrNi 18-10	-
19	Spring washer	Stainless steel EN 10088-3 X5CrNi 18-10	-
20	Nut	Stainless steel EN 10088-3 X5CrNiMo 17-12	-
21	O-ring	EPDM	-
22	Bush	POM-C	-
23	External circlip	Stainless steel EN 10088-3 X5CrNi 18-10	-
24-25	O-ring	EPDM	-

(*) DN150-200 : Stainless steel AISI 316L

ISOLATING VALVES VALVES

DN 150 to 600



06/28/2019

RSEVP21MOT350

Dimensions and mass

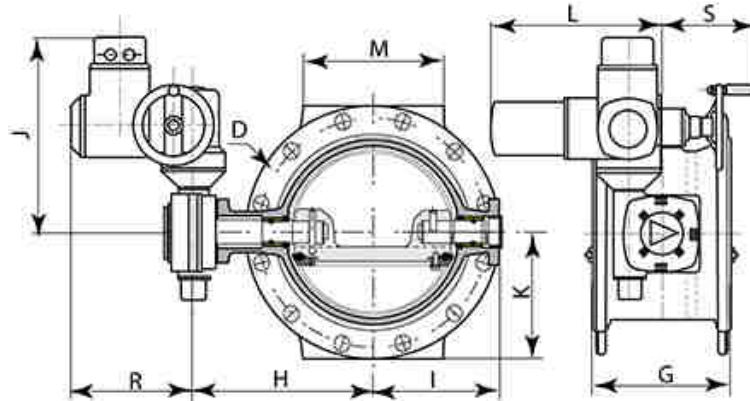

Standard version with short duty actuator S2-15 min, 400 V -3 – 50Hz, IP68.8, KN protection and heater 230 V.

DN	G	H	I	J	K	L	M	D	R	S	Mass
mm	mm	mm	mm	mm	mm	mm	mm	mm	mm	mm	kg
150	210	217	143	389.5	150	315	150	300	238	199	67
200	230	271	185	415	187.5	328	180	375	238	186	94
250	250	299	208	422	225	363	230	450	248	174	128
300	270	323	253	422	257.5	363	250	515	248	174	171
400	310	425	314	549	330	365	310	660	238	149	314
500	350	498	390	556	377.5	408	350	755	248	129	440
600	390	581	466	630	445	443	400	890	248	94	661

Gearbox type and handwheel

DN	Gearbox AUMA type	Actuator AUMA Type	ISO 5210	Operating Time	Speed	Operating Torque
mm				s	turn/mn	Nm
150	GS 50.3 – F10	SA 07.6	F10	35	22	18
200	GS 63.3 – F10	SA 07.6	F10	35	22	41
250	GS 80.3 – F12	SA 10.2	F10	50	16	59
300	GS 80.3 – F12	SA 10.2	F10	50	16	94
400	GS 100.3+VZ4.3 – F14	SA 07.6	F10	69	45	48
500	GS 125.3+VZ4.3 – F16	SA 10.2	F10	98	32	85
600	GS 160.3+GZ160.3 – F25	SA 10.2	F10	147	45	69

Applicable Standards

Hydraulic test

Every single butterfly valve is subjected to hydraulic final test with the purpose of verifying the accordance with the prescriptions ISO 5208:

- Body test at 1,5 time the PFA (open valve);
- Seat test at 1,1 time the PFA (closed valve).

Product test

ISOLATING VALVES VALVES

DN 150 to 600



06/28/2019

RSEVP21MOT350

- Control of coating: test of thickness, holiday test, impact test, MIBK test

Conformity to the standards

Product:

- EN 593
- ISO 10631

Plant test:

- ISO 5208

Flanges dimension:

- ISO 5752 series 14

Flanges drilling:

- EN 1092-2
- ISO 7005-2

Suitability for potable water:

- Italian CM 102 of 02/12/78
- Conformity to foreign norms: KTW (Germany), WRC (U.K.), ACS (France)

Marking

On the body like EN19:

- Nominal diameter in mm (DN);
- Nominal pressure in bar (PN);
- Type of ductile iron;
- Manufacturer's logo;
- Model code;
- Fusion date.

On the label like EN19:

- Nominal diameter in mm (DN);
- Nominal pressure in bar (PN);
- Maximum operating pressure (PFA);
- Closing direction;
- Model code;
- Manufacturing order, Order confirmation;
- Manufacturer's logo.

On the disc:

- Nominal diameter in mm (DN);
- Nominal pressure in bar (PN);
- Type of ductile iron;
- Manufacturer's logo;

ISOLATING VALVES VALVES DN 150 to 600		06/28/2019
		RSEVP21MOT350

- Model code.

The marking of the valves manufactured by Saint-Gobain refers to the EN 1074-2 and EN 19 international standards.

Markings are either integral markings, cast in the body, or markings made on plates, securely fixed to the body, in accordance with the EN 19 standard specifications.

Specifications EN19		Requirements	Saint-Gobain valves process
Table1-Valve markings			
1	DN	EN 19 § 4.2.1 Mandatory markings Shall be integral markings or on a marking plate	Integral
2	PN		Integral
3	Material		Integral
4	Manufacturer's name or trade mark		Plate
11	Reference to Standard	EN 19 § 4.3 Supplementary markings Items 7 to 21 in Table 1 are optional	Integral
12	Melt identification		Integral
16	Quality test		Printed on body
18	Manufacturing date		Plate
21	Closing direction		Plate + sticker on body



Valve selection

The butterfly valves are generally used as isolating devices type on/off. In some particular case, in which there's low differences of pressure and low flow rate variation can be used like regulating devices, considering the hydraulic parameters necessary to avoid the cavitation risk.

To do the right dimensioning of butterfly valve it's necessary to know the followings parameters:

- Upstream hydrostatic pressure (that is the hydrostatic pressure with valve in closed position)
- The maximum speed in water pipe (generally expressed in l/s) or the nominal diameter and the project flow rate from which it is gained the speed $V=Q/A$

ISOLATING VALVES VALVES

DN 150 to 600



06/28/2019

RSEVP21MOT350

Moreover it's necessary to control that the maximum speed in water pipe have to be equal or inferior to 5m/s, and the exercise temperature have to be between 0°C and 40 °C.

Hydraulic features

The head loss Δh are variable in function of valve open degree and can be calculated with the following expression:

$$\Delta h = \frac{\zeta \cdot v^2}{2 \cdot g}$$

with Δh = head loss (m), ζ = head loss coefficient (dimensional), v = nominal speed (m/s), $g = 9,81$ (m/s²)

The head loss coefficient can be estimated from this diagram:

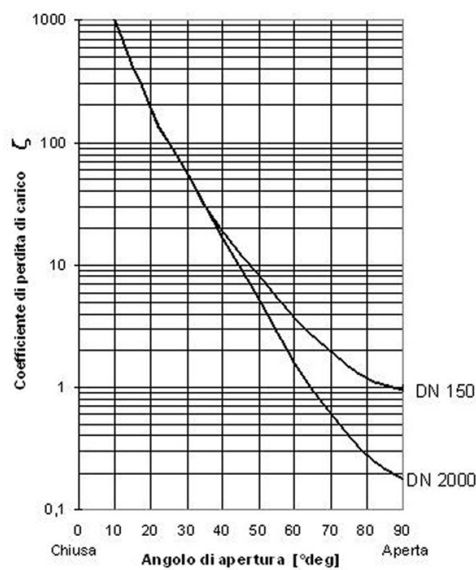

Determinates the head loss Δh it's possible to calculate the flow rate Q in m³/h with the following expression (the same expression can be used to, having the project flow rate Q , to determinate the head loss Δh without using the head loss coefficient):

$$Q = K_v \sqrt{\frac{\Delta h}{10.2}}$$

in which 10,2 is a corrective factor in meters, and K_v is the flow rate coefficient in m³/h, determinable from the following diagram in function of valve open degree:

VALVOLA A FARFALLA - BUTTERFLY VALVE

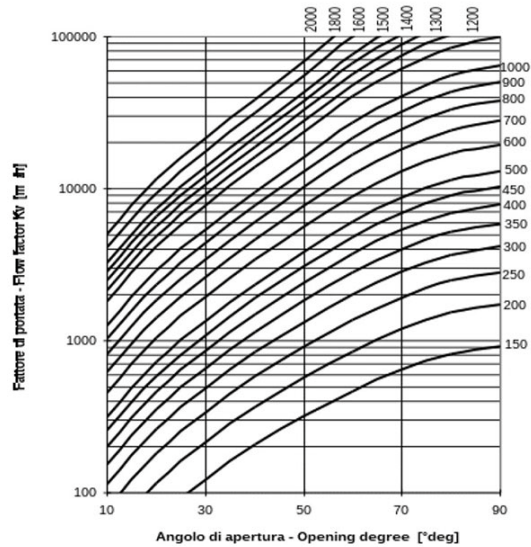

Example: Valve DN600 mm - $\Delta h = 3$ m

From the diagram with valve open to 100% the coefficient Kv is 20000 m³/h. Using this date in the flow rate expression:

$$Q = 20000 \times \sqrt{3 / 10,2} = 10850 \text{ m}^3/\text{h}$$

Otherwise it's possible to calculate the head loss with valve completely open, having the project flow rate Q, in function of DN, using the following diagram:

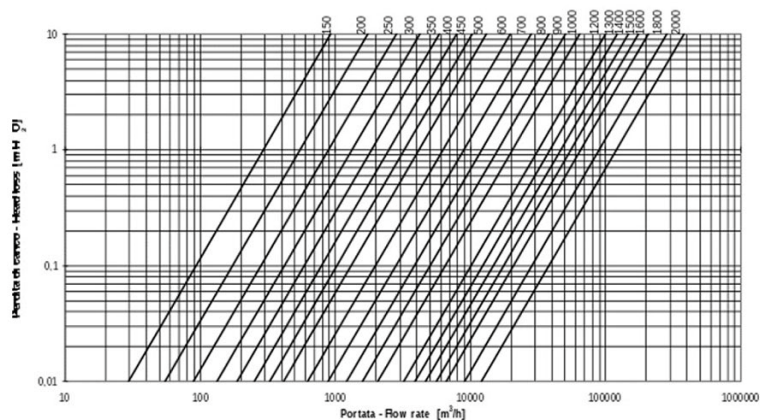

Cavitation

If the butterfly valve is used only like isolating device there's not cavitation risk.

In the particular case in which it's used like regulating device, this can be possible only respecting the following parameters:

- The valve open degree have to be between 30° and 90° (valve completely open)
- The downstream pressure P₂ have to be: $P_2 \geq 0,7 \cdot P_1 - 2,8$ with P₁ upstream pressure.

ISOLATING VALVES VALVES DN 150 to 600		06/28/2019
		RSEVP21MOT350

Instructions for use

Storage

The butterfly valve will have to be held (if possible) in covered places, the most possible protected from the sun (maximum allowable temperature 70°C in accordance to EN 1074), from the rain and generally from the atmospheric agents. Moreover it will have to be avoided that the seal of the same air valves come to contact with powder or earth.

Installation

The butterfly valves are generally installed with retaining ring mounted in the opposite way respect to the direction of flow rate to permit the substitution of gasket without dismounting the valve from pipeline. In any case it is possible to install the butterfly valve with flow rate in opposite direction and also, if required, in vertical position. We recommend to install the butterfly with the operating device on the hydraulic right side of pipeline.

It's possible to install the butterfly valve both in chamber valve that underground (choosing the right configuration).

We recommend to insert a dismounting joint for the operation of maintenance.

Maintenance

The butterfly valve does not require a particular maintenance, all parts subjected to wear are perfectly auto-lubricating. In any case, if for a long time will be not used, it is necessary to evaluate the functioning of valve doing (at least one time for year) some manoeuvre of opening-closing.

All the maintenance operation have to be do after the total emptying of pipeline (no flow rate and pressure) to avoid every risk to the people during this operation.

In presence of particularly exercise condition or damage due to external cause, it will be necessary some maintenance operation. In this case the particular shape of EUROSTOP butterfly valve permits the simple gasket substitution without the dismounting of valve from pipeline (if the dismounting joint is present).

Accessories

To adapt the butterfly valves to the different exercise and installation conditions required, they can be equipped with particular accessories used in combination with control devices: please refer to data sheet for accessories.

The technical features in this document are not contractual and can be changed without preliminary notification due to the continuous technical progress of product.